

**SUSTAINABLE HOMES:**

**TIMBER FRAME HOUSING**



---

**Sustainable Homes**

# CONTENTS

---

Executive Summary	1
Introduction	2
Current Position	3
Technicle Perspective	9
Environmental Perspective	11
Third Party Perspective	13
The Way Ahead	14
Contact Points for Further Information	15
Bibliography	16

## EXECUTIVE SUMMARY

---

- It is estimated that across all the developed countries, timber frame accounts for around 70% of all housing stock, representing some 150 million homes.
- The current capacity of the UK producers is around 35-40000 units per annum.
- Small panel hand erect open panel is the most common system used in the UK accounting for ~80% of the market. More advanced closed panel crane erect systems (as used in other countries) are attracting more attention.
- Both floors and roofs can also be factory produced into panels called cassettes.
- Timber frame is renown for its excellence in energy efficiency terms.
- The acoustic performance of timber frame party walls outperforms masonry by some margin.
- In terms of durability, NHBC records indicate that timber frame homes tend to perform better than masonry homes.
- In terms of sustainability, timber is possibly the *only* renewable resource in the construction sector and contains less embodied energy than comparable building materials.



## INTRODUCTION

The construction sector is a huge consumer of natural resources on a world-wide scale. As housing typically accounts for around one third of construction activities in developed countries, it is little wonder that creating sustainable development in this sector is a priority issue for Governments. The DETR Sustainable framework highlighted adaptability, use of recycled materials (or those from sustainable resources) and minimisation of energy needed to operate buildings as priority areas. In 1998, the Egan report highlighted the role social housing should play in leading the way in quality enhancement for the housing sector and pointed to learning from innovative housing from overseas. More recently, the Housing Forum with its demonstration project programme and the Housing Corporation with the publication of their 9 proxies for Egan compliance also raised the profile of prefabrication in terms of potential waste reduction. These are all issues that are rapidly expanding the UK market for timber frame building systems.

**History** Timber frame housing is not a new concept - even for the UK. For centuries it was one of the most common construction materials and examples of timber framed houses from the 12th century are still in existence today. Softwood based timber housing systems (similar to those in use today) date back to the 1780's with fine examples dotted along the East and Southern coasts. Dramatic growth in market share came in the 1960's and 70's with the industrialised housing boom. In 1982, 27% of all new build homes in the UK were constructed from timber frame. A combination of adverse publicity regarding robustness (since proved groundless) and a slowing of the housing market have seen market share fall in Great Britain to around 6% over the last 15 years. Interestingly, in Scotland the market share has remained between 40-45% of all new-built housing throughout this period. It is estimated that of the ~20 million homes that exist in the UK, around 2 million are constructed from timber frame. The last 18 months have seen a dramatic resurgence in the market with timber frame now accounting for over 8% of all new homes<sup>1</sup>.

**An International View** Other developed countries take an entirely different view from the UK of timber based housing stock. The table below provides a snapshot of current use;

Country	Population (in millions)	Housing Stock (in millions)	Annual Housing starts (000's)	Timber Frame Market Share (%)
Australia	17.84	6.09	135.6	90%+
Canada	29.25	9.91	110.4	90%+
Ireland	3.57	0.87	35.5	10%
Japan	124.96	40.54	1,464	45%
Norway	4.34	1.82	19.2	90%+
Sweden	8.78	3.86	12	90%+
USA	260.71	97.31	1,356	90%+
UK	58.39	21.39	169.2	8%+

It is estimated that across all the developed countries, timber frame accounts for around 70% of all housing stock, representing some 150 million homes.

<sup>1</sup>These figures relate to NHBC statistics on timber frame use. NHBC note that some timber frame homes are privately built and are therefore not registered with NHBC, suggesting the actual market share is larger than the figure indicated.

## CURRENT POSITION

The most common use of timber frame in the UK is as a structural framing system that is then externally clad with brickwork to provide the rainscreen. There are around 100 timber frame manufacturers in the UK and a wide variety of firms that import timber homes to the UK from the Scandinavian countries, Canada and the US. The capacity of the UK producers is around 35-40000 units per annum and an estimated 5-10 new firms entered the market last year. A wide variety of methods of construction and manufacturing systems are used which are explained below.

There are 3 main methods of construction namely;

**Stick built** - Components cut off-site and assembled on-site using simple hand tools. This is most common in Japan, the US and Canada and can also be seen in Scandinavian countries in the summer months. Generally in the UK its use is restricted to post-and-beam type construction shown in illustration 1 below.

### Methods of Construction

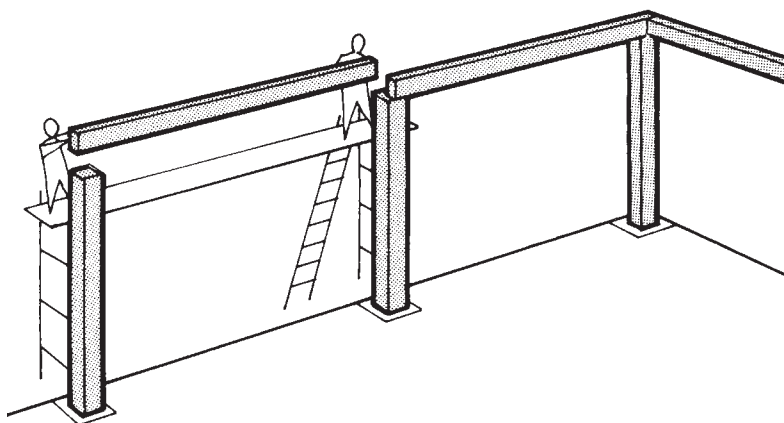

Illustration 1: Post and Beam "stick-built" construction

**Hand erect (Small panel)** - Components are assembled off-site in timber frame factories. The softwood timber studs are made into panels (typically between 2.4-3.6 meters long) and up to 2.4 metres high. They are then sheathed on one side with a timber panel product like plywood or more commonly Oriented Strand Board (OSB). This is then finished externally with a breather membrane and delivered to site where the panels are hand manoeuvred into position and nailed together using nail guns (see illustration 2 below).

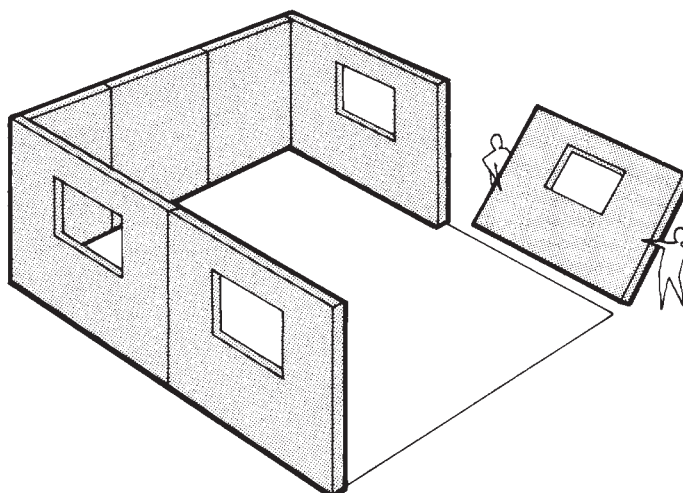
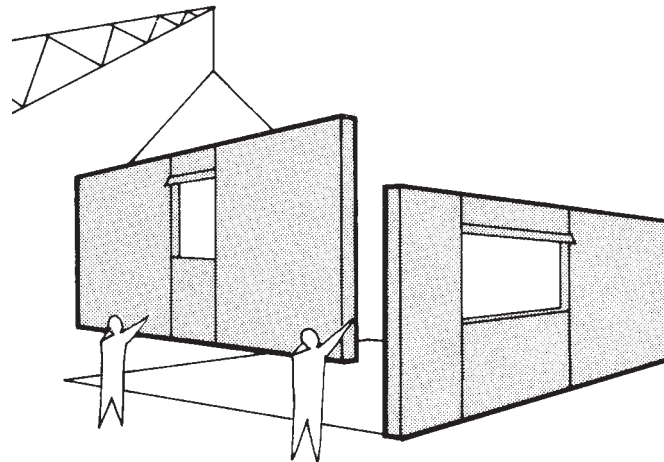
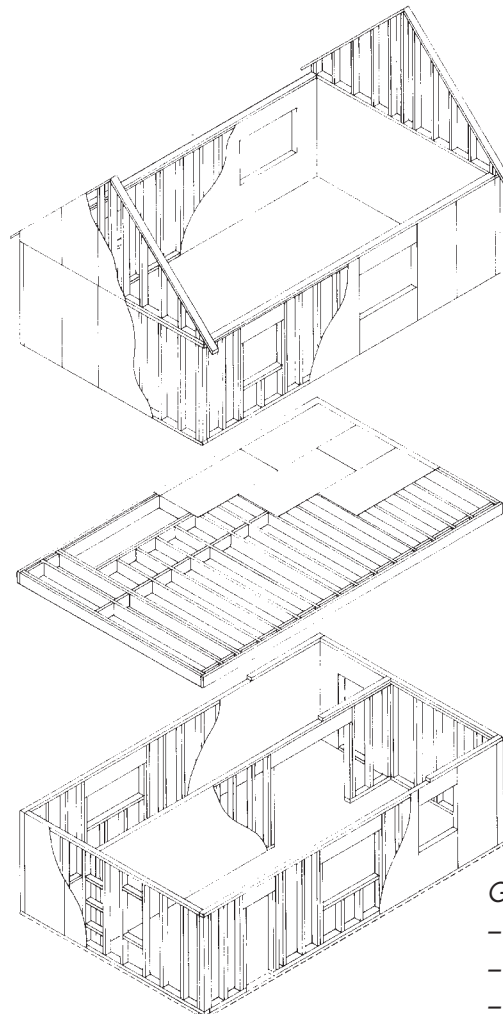

Illustration 2: Small panel hand erect construction

**Crane erect (large panel or whole-room)** - Similar to small panel only the panels can be up to 9.6 metres long and require a crane to erect them as they are too heavy to manoeuvre by hand. The most common form of construction (large or small panel) is generally referred to as **platform frame** as the wall panels form a platform (see illustration 3 below) on which the next storey wall panels sit. Crane erect also enables the use of whole-room construction or volumetric techniques discussed below.



*Illustration 3: Large panel crane erect construction*



*Ground floor construction may be a:*

- Ground supported concrete slab
- Suspended timber floor
- Suspended concrete floor

*Illustration 4: Platform frame exploded view*

There are 3 main generic manufacturing systems in use in the UK. These are;

**Open Panel (Conventional Platform frame)** - This system and has a 35-year track record in the UK market, and many more in North America. It performs well against all types of measure and NHBC statistics would suggest extremely low claims ratio in respect of defects. The panels are made 'open' on one side to receive insulation on site and are 'closed' by the drylining material. This system probably accounts for 80%+ of timber frame used in the UK. The general build up of a platform frame is shown in illustration 4 and a typical wall section in illustration 5.

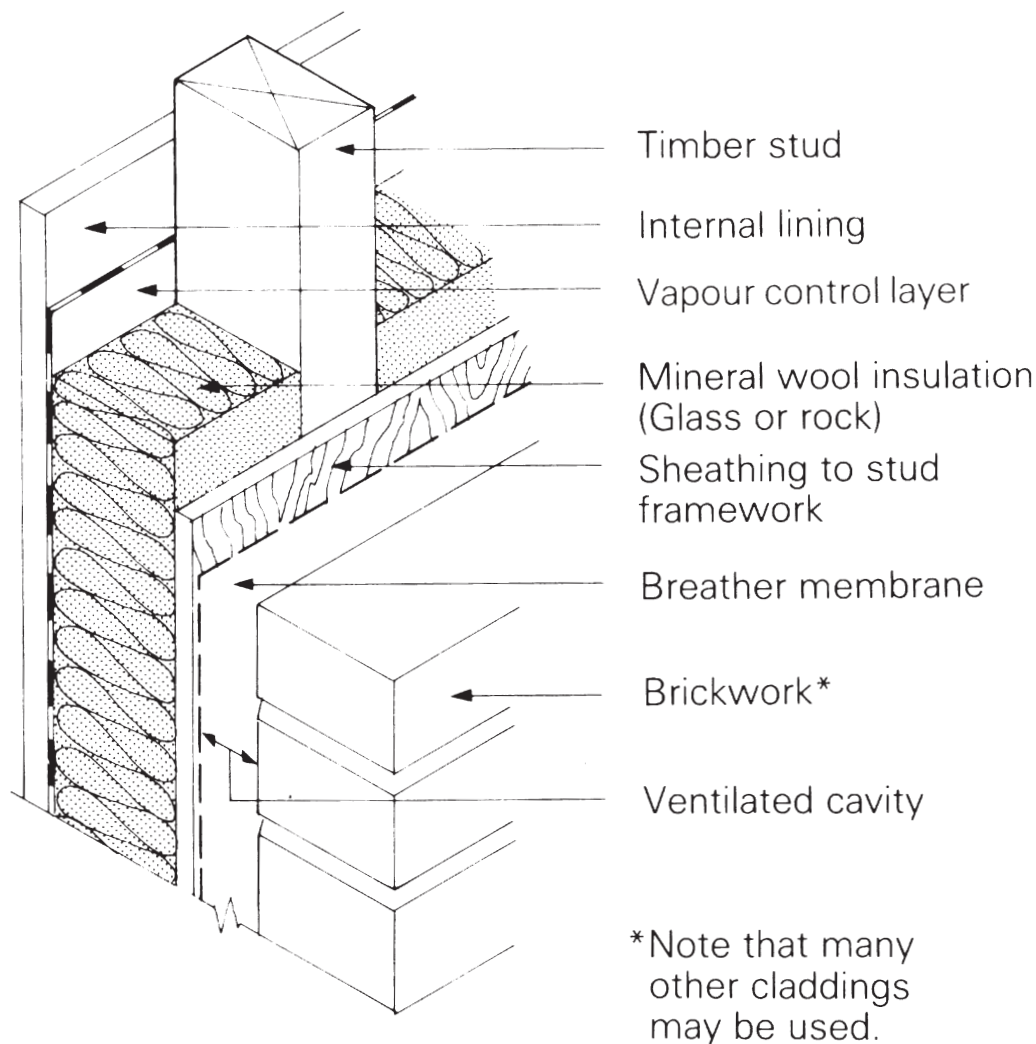

*Illustration 5: Platform frame wall section*

**Closed panel systems** - Here the insulation material is installed into the panel in the factory and this is then retained with some other layer of material to 'close' the panel. Closed panel systems generally allow more value to be added in the factory but often require service runs to be pre-planned. As they are also heavier, they tend to require crane erection on site. The illustrations here show 2 generic types often referred to as breathing walls. 'Breathing' in this context, relates to water vapour diffusion. In essence, all timber frames breath to avoid interstitial condensation. Here however, the vapour control layer is incorporated into the plasterboard as a backing and the soft, or medium-board outer sheathing does not require an additional breather membrane as found on conventional platform frame (see illustration 6).

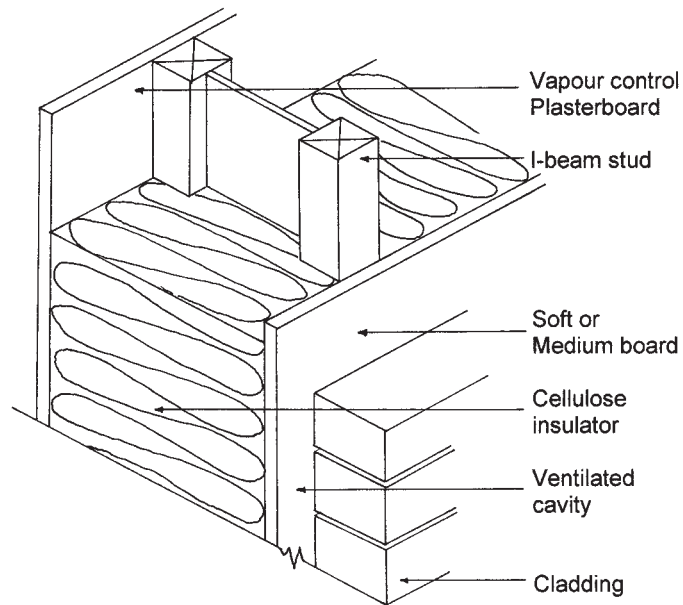

*Illustration 6: Closed panel wall section*

Illustration 7 shows the latest development in timber frame panels - a reverse wall. Here the structural OSB sheathing moves to the inside face to improve robustness (rather than just acting in a structural capacity externally) and also acts as a vapour control layer. The external material can be moisture resistant plasterboard, medium board or soft-board, or even a breather membrane, dependant on the application (i.e., if factory fitting cladding, a breather membrane would provide a low-cost solution). Both systems are compatible with all external claddings.

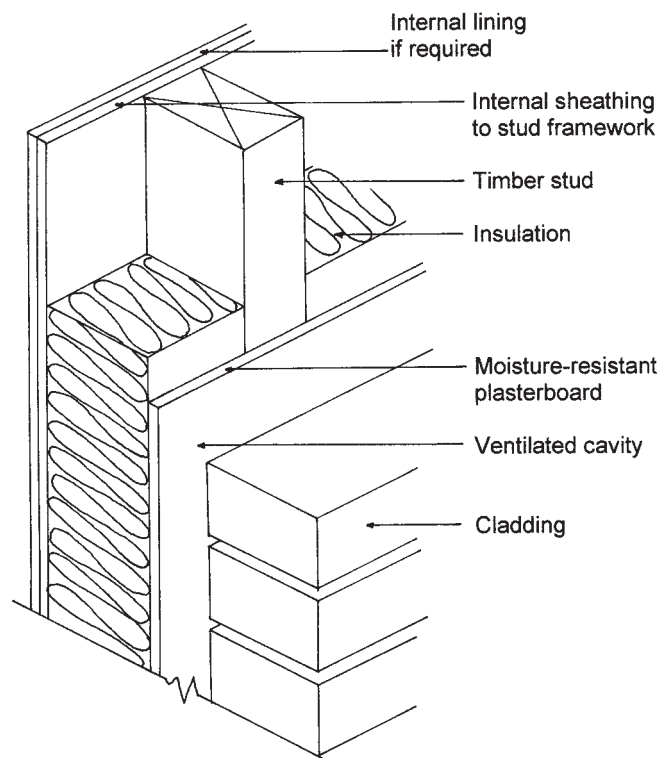

*Illustration 7: Closed panel reverse-wall*



**Volumetric** - Here large elements of the structure are assembled off-site to form typically whole rooms. These can be complete to include all furnishings, carpets and fittings, etc and are craned into position on site where final connections for services are made. Rooms are typically no more than 3.6 metres wide due to transport restrictions. This system is currently used primarily in the commercial hotel sector for it's speed of erection (see illustration 8 below).

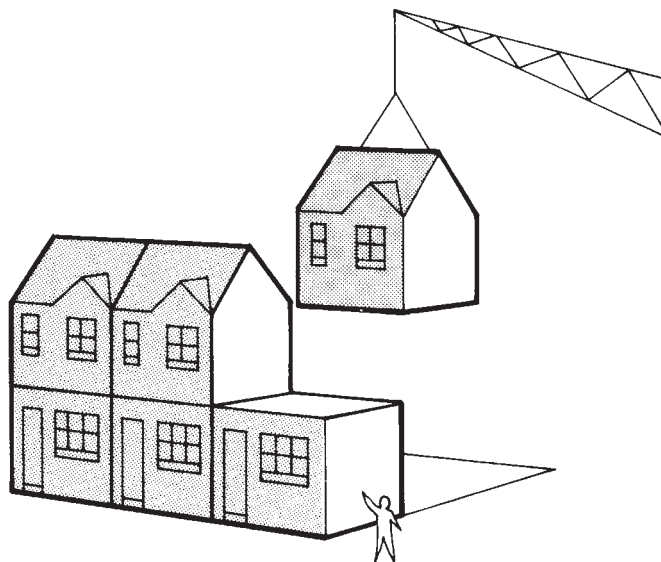

Illustration 8: Volumetric (whole room) construction

Floors are most commonly supplied as cut to length timbers and assembled on-site in much the same way as with masonry construction. However, more recent developments include pre-fabricating the floors into panels in the factory (called *cassettes*) and delivering them for crane erection as with the wall panels. These cassettes typically comprise the floor joists, and decking material, but can also include insulation and drylining to the ceiling side. With compartment floors for flats, these are then finished on-site with a *floating floor* to provide the improved acoustic barrier. When combined with engineered wood products like I-beams, clear span floors of over 6 metres can be readily achieved, allowing complete freedom over internal layouts and future adaptability. As laying a site-cut floor can take a half to one day for a single home, these cassettes can offer dramatic productivity improvements.

Roofs are traditionally the same for all forms of construction i.e., truss based. Over the past 25 years this form of prefabrication has become the norm in the UK and site-cut roofs are only seen on the most complex of structures. Whilst the truss roof system is efficient and economical to construct, they do largely prevent future access to this space. Attic type trusses are often used to overcome this problem. Similarly, roof cassettes are becoming a more common sight, enabling faster watertight construction times and allowing complete access to the roof space.

Timber frame systems are designed to operate to tight tolerances so lend themselves to the use of IT. Most manufacturers in the UK will operate Computer Aided Design (CAD) software to take bespoke schemes and produce timber frame solutions. These produce panel layouts, material take-off and cutting lists. In some instances the software also controls the saws in the factory to optimise the useful material from each piece of timber and minimise waste.

## Floors and Roofs

## Design

It is important for designers and clients alike to understand that timber frame can provide flexible design solutions, rather than rigid boxes often portrayed. Conversely, it is also necessary to expect that to reduce waste (materials, labour, design time, etc) it will be necessary to work with standard components wherever possible to maximise the manufacturing efficiencies (i.e., use of standard size sheet materials to dictate room heights rather than brick coursing).

**Manufacture** In the UK at least, there is currently little use made of full CAD/CAM (Computer Aided Manufacture), although as the market expands this position is likely to change. Most manufacturers use production lines to assemble the panels. These are usually labour based and a factory producing around 1000 homes per annum might employ around 60-70 trained operatives working on 3-5 lines. Standard panels are produced on the production line and the more complex elements (like window openings) are often completed as sub-assemblies. It typically takes around one to one and a half day's production time to produce one standard house that would consume around 10 person days of labour. Completed panels are then loaded in reverse order onto trailers so that the first panels unloaded are the first panels required on site. As the designs have to be complete prior to manufacture, the lead times are longer with timber frame and 6 weeks would be the norm.

One of the most commonly identified advantages of timber frame systems is in relation to thermal performance. Whilst issues like ventilation, orientation and heating systems influence thermal performance, the most important factor by far is the structural envelope. Timber frame is renowned for its excellence in energy efficiency terms. This is due to the insulation forming an integral element of the system. 'U' values in even the most basic timber frame home will exceed current building regulation requirements. Similarly, future changes to building regulations are more readily accommodated with timber frame as perhaps the greatest advantage in thermal efficiency terms is timber frames flexibility. If more energy efficient structures are required it is simply a case of increasing the thickness or type of the insulation product. Three 'standards' are available for wall thickness, an 89mm stud (to meet current Building Regulations), a 140mm stud (to produce a U value of up to .25 W/m<sup>2</sup>K) and an 'I' beam wall (start at 175mm thick to produce U values of .1 - .18 W/m<sup>2</sup>K). In general it is advisable to keep the 'U' value specification broadly similar for walls and ground floors.

### Thermal Performance

As the structures are assembled from components made to manufacturing tolerances, the better fit achieved improves air tightness and hence positively effects energy efficiency. Timber frame buildings also have a *low thermal capacity* i.e., they heat up quickly and therefore provide comfortable, energy efficient homes that meet today's lifestyles. In terms of NHER ratings or SAP scores of 10 and 85-100 respectively are frequently achieved.

Noisy-neighbours has become an increasingly common environmental complaint and those who have suffered it comment on the misery it causes. The party wall used in timber frame (i.e., the wall that separates adjoining buildings) outperforms masonry party walls by some margin.

### Acoustic Performance

Sound travels in and between buildings in two main ways; Firstly *airborne sound*. This is addressed using a combination of dense wall linings (plasterboards) and absorbent quilts to reduce (by absorbing) sound available to be transferred. Secondly *structure borne* sound. This is addressed using the concept of *structural discontinuity* i.e., ensuring that adjacent dwelling structures are structurally independent of each other so that sound cannot travel directly across solid objects from one building to another.

All buildings are designed to comply with government Building Regulation requirements for acoustic performance however, these rely on building detailed designs that have been proven to work. The problem is obviously one of site control to ensure this happens. Achieving standard detail designs with frame structures has a distinct advantage in that separating structural elements like walls and floors can be built to factory quality standards using tested solutions. Independent studies have highlighted that timber frame party walls tend to outperform their masonry equivalents by some margin.

Having fresh clean air in buildings is a concept anyone can grasp as important. The problem for clean air in design terms is separating the planned air changes (ventilation) from the unplanned air changes (infiltration) like drafts through cracks and gaps in the building structure. Clearly the control of infiltration is an important design element for structures, as this will dictate their thermal performance and running costs. Air sealing in timber frame homes is controlled by tightly fitting structural panels with overlapping plasterboard linings and is assisted by the vapour barrier that lies behind all internal wall linings. This vapour control layer also prevents the risk of harmful condensation occurring within the wall structure.

### Air tightness

With or without this membrane, as long as the vapour resistance relationship between the warm and cold side of the wall is at least a factor of 5 (greater on warm side) condensation will not occur. These factors combine to create a structural envelope that is considerably more air sealed than conventional construction.

### **Fire Resistance**

The UK Building Regulations apply to all forms of house construction. Timber frame homes tested to BS476 demonstrate that they exceed these requirements. The 'Charring predictability' (i.e., it chars at a known rate) of timber in fire situations means the building performance can be more accurately predicted.

The plasterboard linings and fire stops or cavity barriers typically provide fire resistance. As these are installed on site there are important site management issues to consider ensuring correct installation.

### **Durability**

Timber frame has been the victim of many scare stories in relation to durability. Most notably the 'World in Action' programme of 1983. Two large-scale independent stock surveys conducted by the BRE and published in 1993 and 1996 respectively "found no instances of rot caused by water ingress". Rain penetrating exterior claddings is removed via the special 'weep-holes'. The breather membranes provide additional security. Since these stories were conducted, all timber in exposed areas (i.e. in cavity), are also preservative treated to ensure additional peace of mind. The use of preservative treatments in the UK is a requirement of NHBC, Zurich and HAPM alike (interestingly, it is not a requirement in other countries like the US or Sweden). NHBC records indicate timber frame tend to perform better than masonry homes. In fact claims were so low they stopped keeping separate records in 1985.

Durability in terms of internal robustness of the linings is often perceived as a major concern for timber frame use. Alternative timber frame solutions are available to counter this perception such as the reverse wall mentioned earlier.

## ENVIRONMENTAL PERSPECTIVE

As mentioned, the construction sector is a major consumer of natural resources (land, minerals, trees, etc.). It is therefore, one of the industries highlighted as needing to address the environmental impact of its trading activities and implement "Sustainable Development". The HMSO publication on Sustainable Development identifies the problems and opportunities as below;

"Practices such as energy efficiency, recycling and use of sustainable materials and products need to become inherent parts of the design and construction process, and in some cases, displace traditional construction processes and practices"

For construction, the sustainable development framework has been defined as;

- **Refurbishment, adaption and reuse of buildings** - timber frame can be utilised here to retain existing facades via use of drop-in prefabricated "rooms" to maintain existing street lines or, use of prefabricated 'retro-fit' packages, or bringing existing roof space into habitable use via panel based replacement roofing solutions.
- **Design and construction of new buildings which can be adapted to different uses, thereby extending their lifetime** - Clear span floors built from engineered wood products like 'I' beams allow adaptability of layouts and innovative panel based roof structures allow future expansion into loft space, allowing simple future adaption by occupiers.
- **Use of recycled components and materials, or those from sustainable sources** - Timber from well managed forest which have a planting regime that replaces plants at least in the same ratio as they are removed, can contribute significantly to global CO<sub>2</sub> reduction. Similarly, innovative use of products that can be made from recycled materials, like OSB board materials or "I" beams, can enhance the environmental footprint of the home.
- **Minimise the energy needed to operate a building** - Using materials that have a low product energy requirement (embodied energy) in the construction like timber can contribute significantly to CO<sub>2</sub> emissions reduction. Similarly, designing well insulated, air-sealed buildings that require little energy consumption to maintain comfort levels (i.e., highly insulated wall and roof panels), reduce fossil fuel consumption over the lifetime of the building.
- **Reuse or recycling of wastes produced during construction and demolition** - This is perhaps timber frames strongest environmental credential in that use of off-site manufacture will reduce the opportunity for waste to occur on site. Waste produce in a factory environment is easier to manage through reuse in manufacture, fuel or sorting for sale for secondary uses.

So, the need to create more 'sustainable' developments that utilise low-embodied energy materials/production techniques that are thermally efficient for owner/occupiers will drive the change towards the specification of more renewable resources and "leaner" construction practices. A brief look at the credentials of timber frame in this context is outlined below.

Timber is possibly the only renewable resource in the construction sector. Forest planting regimes are typically 2 for every 1 removed which, coupled to tax breaks (on forest planting in the 1950's) mean that even the UK timber resource is set to double over the next 15 years. The UK is already around 20% self-sufficient in timber supply for the construction sector. This new resource provides a massive natural local commodity for UK Plc with the added potential for reduced transport costs associated with imported materials.

**Renewable  
Resource**

**CO<sub>2</sub> Emissions** Buildings account for 50% of all CO<sub>2</sub> emissions and an average house in the UK produces 7.5 tonnes of CO<sub>2</sub> every year. Even a house built to current UK building regulations produces 4.0 tonnes. It is not therefore, difficult to see the benefits of increasing the insulation capacity of the building envelope as one mechanism for reducing the amount of fossil fuel required in running our homes. So for most materials the issue is limiting the CO<sub>2</sub> consumed during the buildings lifetime. Whilst this is also true for timber, selecting this as the key structural material also allows us to think bigger.

Most people are aware that trees are essential for maintaining equilibrium within the natural environment. The reason for this is that during growth they are a **net consumer of CO<sub>2</sub>**, i.e., they act as a 'carbon-sink' removing it from the atmosphere. However, once mature they absorb far less, so a well-managed harvesting regime is necessary. Serious consideration should be given to the wider benefits of constructing on a greater scale with such renewable resources.

Whilst new build housing is often viewed as having only a tiny impact on environmental indicators (only 1% of housing stock in any year will be new build) research shows otherwise. If all UK stock over the last 50 years had been built to today's timber frame standards 300,000,000 tonnes of CO<sub>2</sub> production would have been saved.

**Embodied Energy** This is the energy consumed during the manufacture of a product (sometimes called the product energy requirement). Research has indicated that timber frame walls consume around 58% of the energy required to produce a lightweight block wall. In terms of intermediary floors the figure is just 35% when compared to concrete.

**Running Costs** It is important to appreciate that the running costs of a home are primarily defined by the lifestyle habits of the occupants and the heating system installed in the property. In a typical home, over half the fuel used will be for space heating and hot water. Timber frame's contribution here is to provide an enclosure that is highly insulated with little unplanned ventilation. The rapid thermal response time of the building structure (i.e., it heats up quickly and stays warm longer) also reduce heating need under normal conditions. Typical energy use for a house built to 1995 Building Regulation standards has been estimated at 16035 KWh of which, almost half is used for space heating. Use of a superinsulated timber frame (140mm walls) could halve this requirement.

## THIRD PARTY PERSPECTIVES

*"The NHBC inspects and insures many thousands of homes every year. Our claims records actually show that these (timber frame) houses tend to perform better than masonry homes, as more of the dwelling is made under closely controlled factory conditions"*

**Warrantors  
View**

Christopher Mills, Director of Technical services, NHBC.

Insurance companies also tend not to differentiate between timber frame homes and brick/block constructed ones, stipulating only that:

*"the external roof covering should be of tile, natural or mineral slate or concrete."*

(The Association of British Insurers).

Despite common perception, mortgage lenders do not discriminate against timber frame. Similarly, property surveyors make no distinction.

**Funders View**

*"I am often asked whether there is a difference in value or marketability with regard to timber framed housing and the answer is definitely no."*

Peter Hales, Chief Executive, Countrywide surveyors.

The Housing Corporation has also recently raised the profile of timber frame by its inclusion within their Guide to the allocation process. Timber frame prefabrication is cited as an example of demonstrating compliance with 1 of the 9 Egan Compliant 'proxies' (prefabrication and standardisation).

In a survey of Local Authorities and Housing Associations conducted in 1994 (on behalf of the Timber and Brick Consortium) comparing timber frame stock with masonry stock, 58% indicated timber frame was on a par and 42% indicated it was better. Interestingly, none felt it was worse.

**RSL View**



## THE WAY AHEAD

Clearly timber frame is not a panacea: It will not cure all the ills of the construction sector and lift its overall performance. Similarly, it is not appropriate for all clients, all sites, all scheme designs or all consumers. However, there is a strong case for investigating the timber frame approach, where it is appropriate for use and it's potential impact for creating sustainable homes. In this context we make these recommendations:

**Set Benchmarks** - Using your own internal sustainable homes criteria (be they environmental, economic or socially driven), establish benchmarks for your existing construction technology and assess timber frame against these.

**Learn** - Identify someone within your organisation to obtain the appropriate corporate knowledge on house building technology. Speak to others in your sector using the technology about strengths and weaknesses.

**Consult** - Speak to manufacturers first, before you start designing schemes using timber frame - they may be able to help reduce cost or offer alternative suggestions conducted for other clients in your sector. Involve consumers, funders, maintenance staff, etc to get a holistic view of potential use.

**Trial** - commit sites (consecutive) to the process so that your team become familiar with the approach and can build on lessons learnt on one site to the next.

**Monitor** - Agree a benchmarking framework to assess each completed scheme.

*This paper was prepared for Sustainable Homes by:*

*Simon Palmer  
The Palmer Partnership  
The Clock House  
Yotes Court  
Mereworth  
Maidstone  
Kent ME18 5JQ*

*Tel/Fax: 01622 817107*



## CONTACT POINTS FOR FURTHER INFORMATION

---

### **Building Research Establishment**

Garston, Watford, Herts WD2 7JR  
Tel: 01923 664212 · Fax: 01923 664089

The UK's independent research body for the construction and material sectors

### **Construction Best-Practice programme (CBPp)**

PO Box 147, Bucknalls Lane, Garston, Watford WD2 7RE  
Tel: 0845 605 55 56 · Fax: 01923 664690

The governments Construction Best-Practice Programme for construction

### **SCOTFI (Scottish Consortium of Timber Frame Industry)**

TRADA Offices, John Player Building, Stirling Enterprise Park, Springbank Road, Stirling FK7 7RS  
Tel: 01786 445075 · Fax: 01786 474412

Scottish trade association for timber frame construction

### **The Housing Forum**

108-110 Judd Street, London WC1H 9NT  
Tel: 020-7813 3050 · Fax: 020-7813 3060

Government supported organisation to promote best-practice and innovation in housing

### **TRADA (Timber Research & Development Association)**

Stocking Lane, Hughenden Valley, High Wycombe, Bucks HP14 4ND  
Tel: 01494 563 091 · Fax: 01494 565487  
Contact: Mr Geoff Pitts, Chief Architect

Research and consultancy on timber in buildings

### **Timber & Brick Information Council**

Gable House, 40 High Street, Rickmansworth, Herts WD3 1ES  
Tel: 01923 778136 · Fax: 01923 778136  
Contact: Mr David Scott, Technical Director

England and Wales trade association for timber frame construction

*Illustrations courtesy of TRADA (Timber Research & Development Association),  
Stocking Lane, Hughenden Valley, High Wycombe, Bucks HP14 4ND*

## BIBLIOGRAPHY

*Advanced Housing: Integrated design in the specification of low-energy housing.* Seminar proceedings, Nov. 1998.

*British Gypsum Guide to Timber Frame Construction.* British Gypsum, Loughborough, Leics. 1998.

*Building a sustainable future.* DETR Energy Efficiency Best-Practice Programme. 1998.

*Environmental Standard: Homes for a greener world.* BRE, Watford. 1995.

*Medium-rise timber frame: A best-practice benchmarking guide.* Palmer S. & Heriot R. - TRADA Technology Ltd, High Wycombe, Bucks. 1999.

*Energy Efficient Housing - A timber frame approach.* Pitts. G. - TRADA, High Wycombe, Bucks. 1989.

*Potential carbon emission savings from energy efficiency in housing stock.* Shorrock L. D. - 1995.

*Surveys of timber frame houses.* TRADA WIS sheet 10. 1992.

*Sustainable housing - meeting the challenge.* Conference proceedings, NHBC. 1998.

*Timber frame housing maintenance performance survey.* Timber & Brick Information Council, 1994.

*Timber Frame Construction.* TRADA, High Wycombe, Bucks. 1994.

*Whole building research: the latest developments.* 3rd Cardington Conference, November 1998

Images courtesy of the Timber Research And Development Association (TRADA).



## Sustainable Homes

Hastoe Housing Association  
Harlequin House · 7 High Street · Teddington · Middlesex TW11 8EE  
Telephone 020-8943 4433 Fax 020-8943 2163  
Website: [www.sustainablehomes.co.uk](http://www.sustainablehomes.co.uk)  
Email: [info@sustainablehomes.co.uk](mailto:info@sustainablehomes.co.uk)

PROMOTING ENVIRONMENTAL POLICIES IN HOUSING